

# Transfer Steps Install Instructions

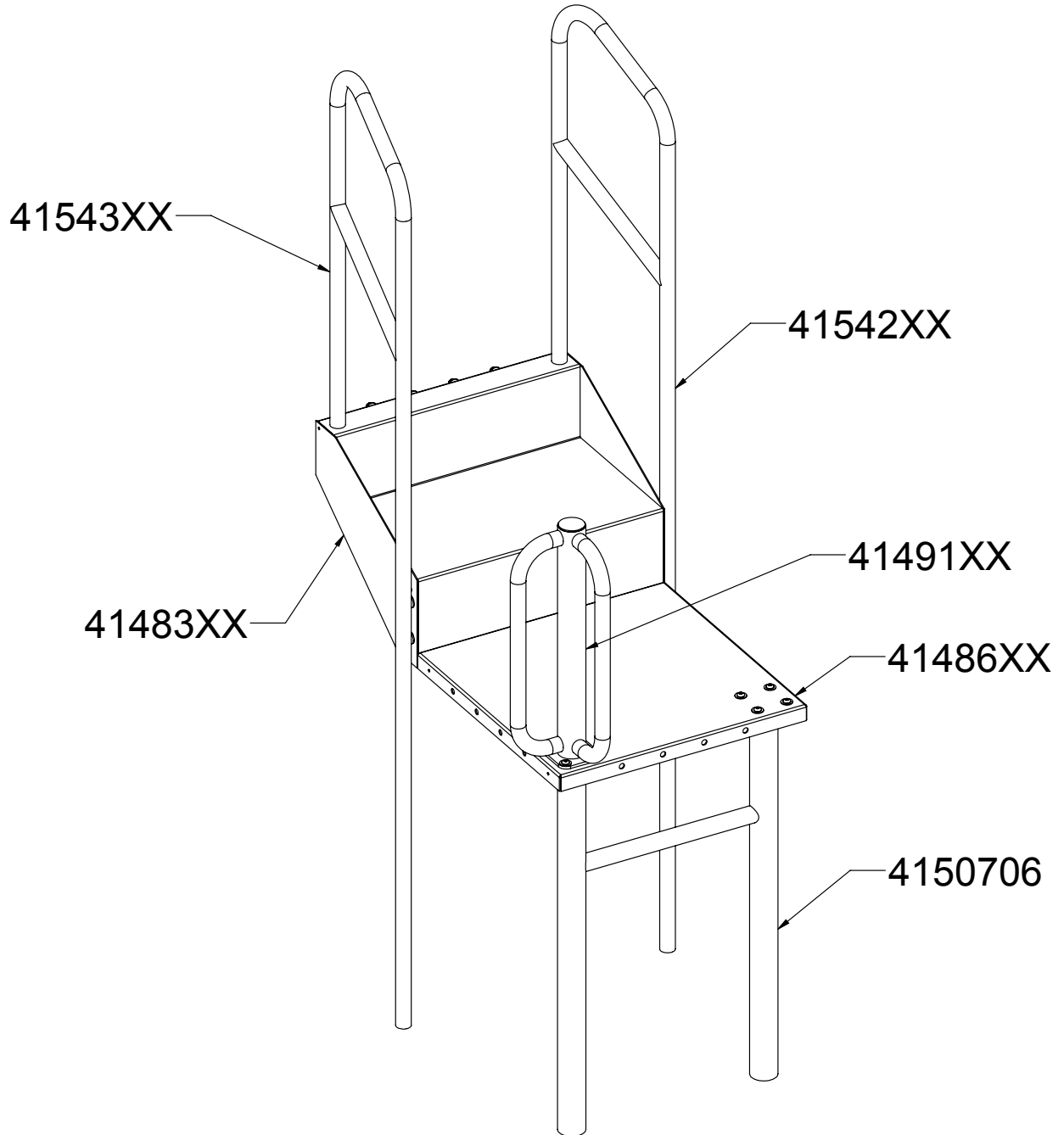

Xccent Play - [www.xccentplay.com](http://www.xccentplay.com)  
5240 257th St, Wyoming, MN 55092  
(800) 933-4748 Fax: (651) 462-9299

# Transfer Steps Assembly

## Step 1

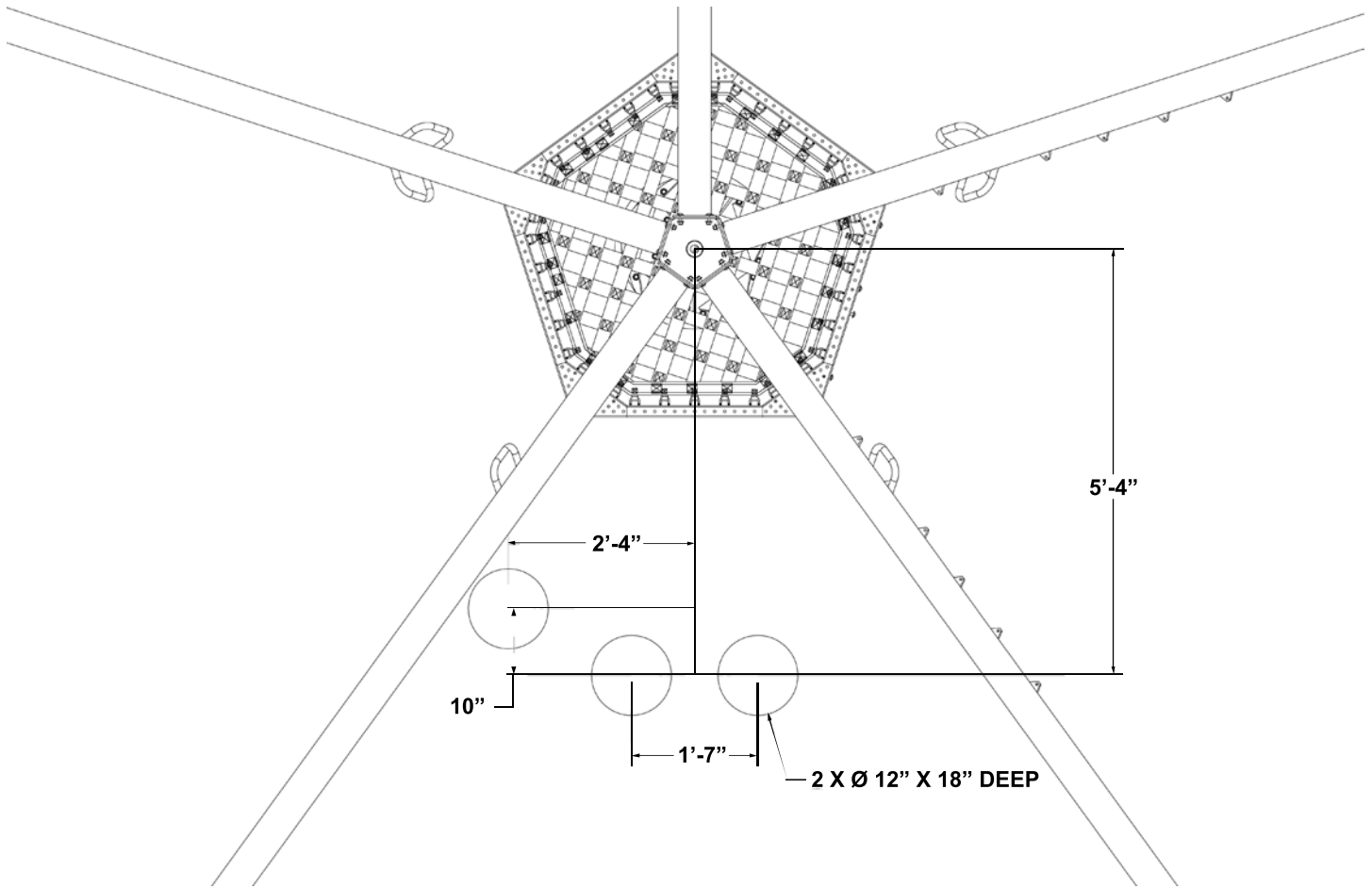

Lay out transfer stair footing holes according to diagram. Drill four Ø12" x 18" deep holes for concrete footings.

# Transfer Steps Assembly

## Step 2

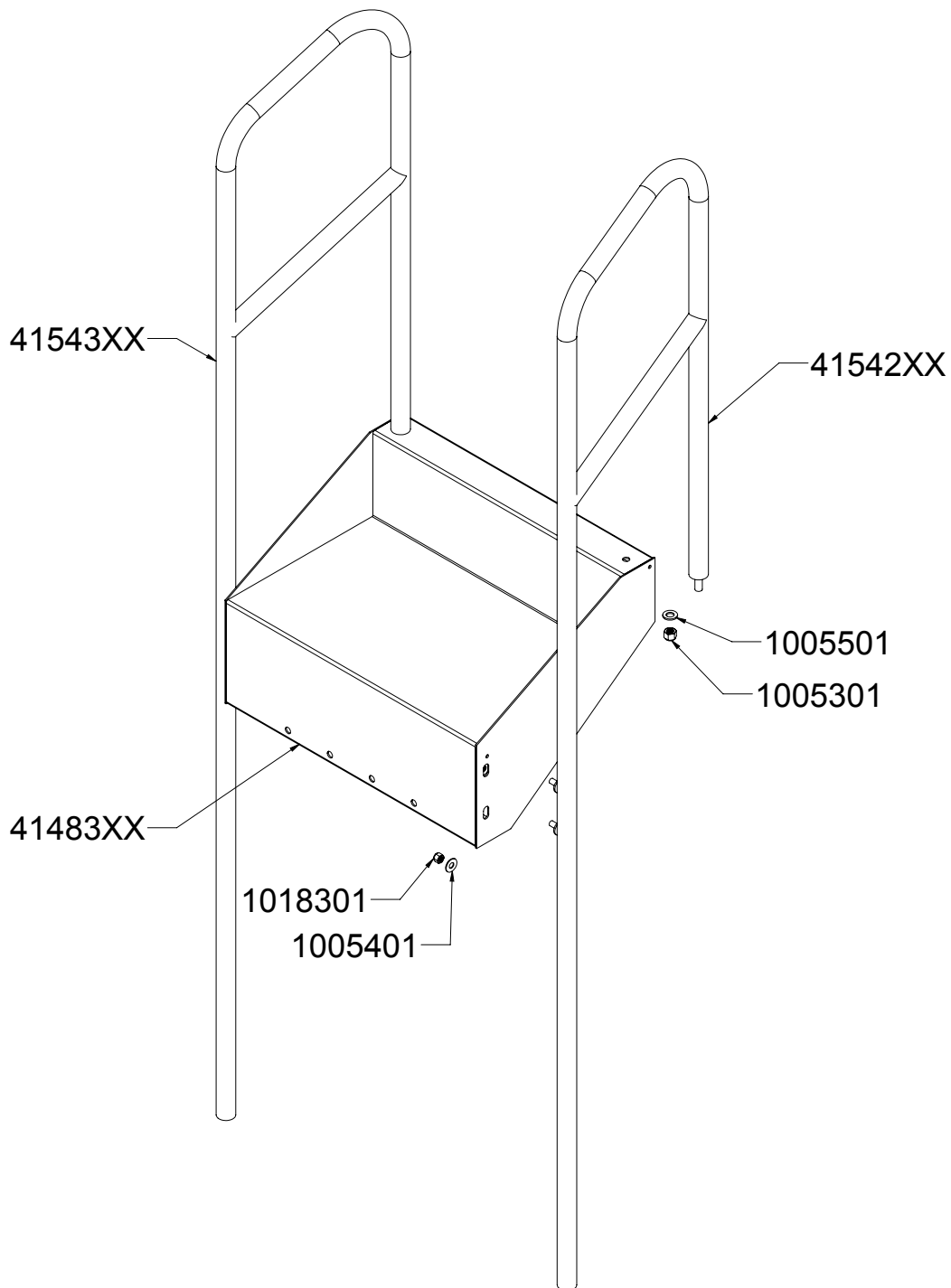

Locate the transfer stair bolt package (4149301).

Bolt the right hand rail (41542XX) to the transfer step (41483XX) using two 3/8" nylock nuts (1018301) and washers (1005401) and one 1/2" nylock nut (1005301) and washer (1005501). Repeat with the left hand rail (41543XX).

# Transfer Steps Assembly

## Step 3

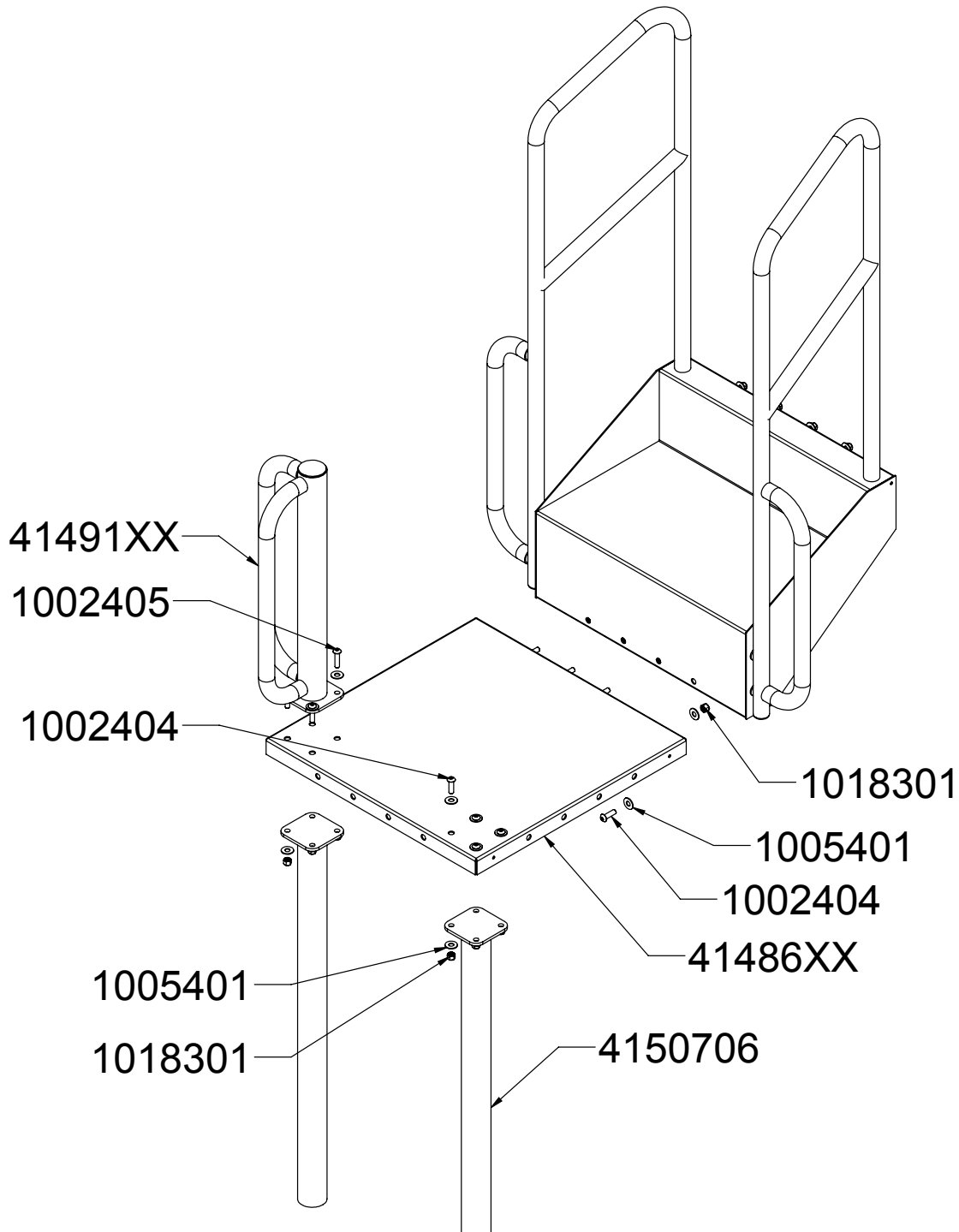

Bolt the transfer deck (41486XX) to the transfer step (41483XX) using four 3/8"-16 x 1.25" BHCS (1026504), eight washers (1005401) and four nylock nuts (1018301).

Bolt the transfer support (41491XX) to the left corner of the transfer deck (41486XX) and one side of the in-ground mount (41507XX) using four 3/8"-16 x 1.5" BHCS (1026505), eight washers (1005401) and four nylock nuts (1018301).

Bolt the second side of the in-ground mount to the right corner using four 3/8"-16 x 1.25" BHCS (1026504), eight washers (1005401) and four nylock nuts (1018301).

# Transfer Steps Assembly

## Step 4

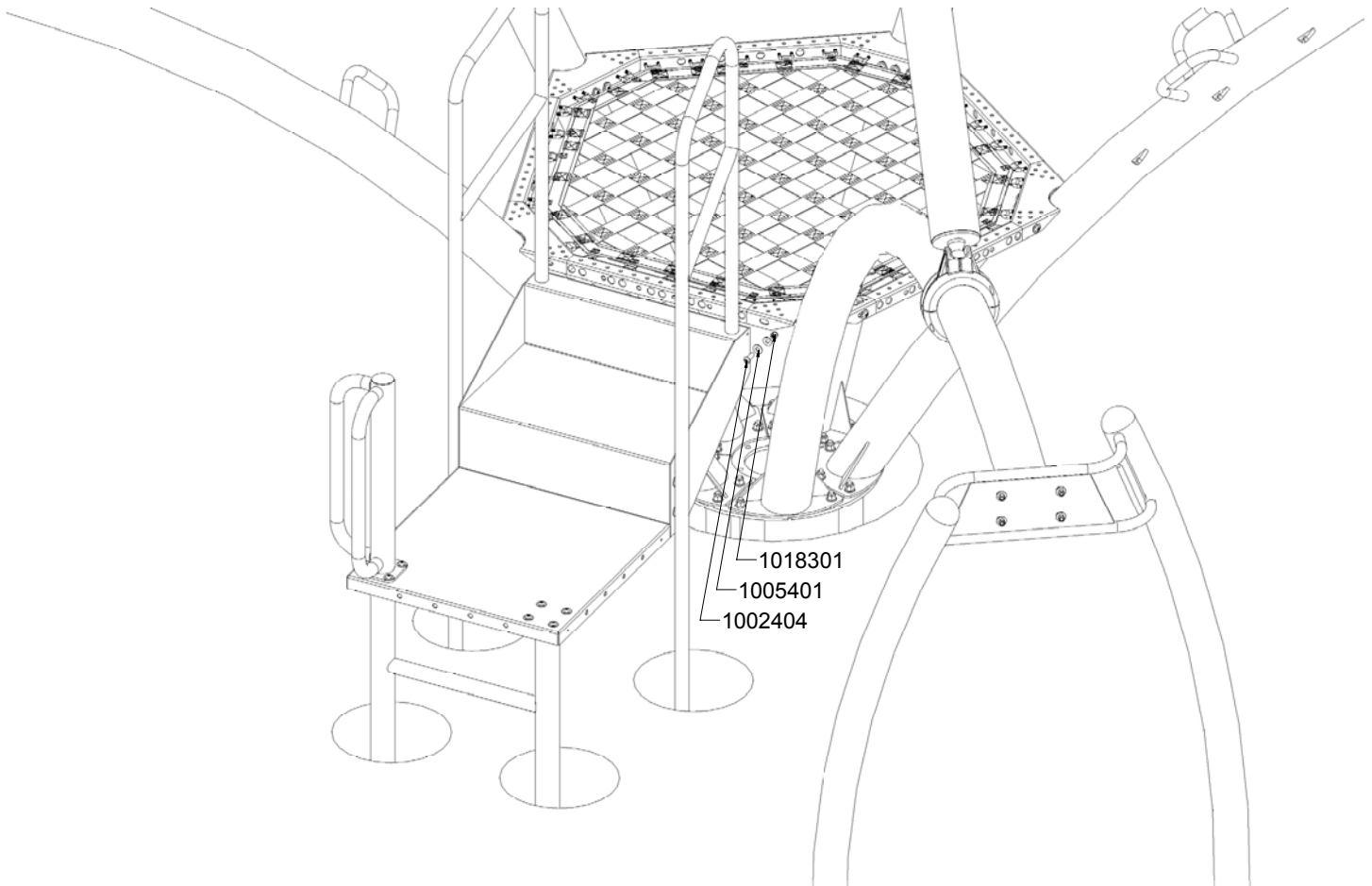

Place the in ground mounts into the footing holes and bolt the transfer step and deck assembly to the Fusion center deck using four 3/8"-16 x 1.25" BHCS (1025604), eight washers (1005401) and four nylock nuts (1018301).

Verify the steps and deck are level and fill holes with concrete. Allow concrete to fully cure before putting equipment into service.